

Zebra's 3S40 3D Sensor

High-resolution 3D imaging for static dimensioning, inspection and depalletization applications

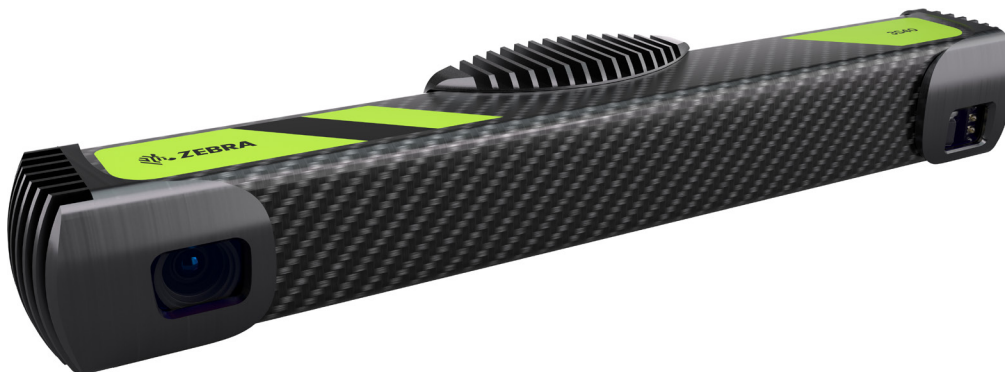

Manufacturing and logistics operations need to move more products more quickly without compromising yields, quality or efficiency. Deploying 3D imaging scanners can increase manufacturing productivity and logistical throughput. But as businesses manufacture and ship products of every size and shape, they need machine vision technology to handle ever larger items.

Zebra's 3S40 3D Sensor Is the Answer

Offering a substantial 3D scanning volume, Zebra's 3S40 3D sensor delivers unparalleled resolution and accuracy to enable depalletization as well as static dimensioning and inspection of oversized items.

Structured light technology enables the 3S40 3D sensor to acquire 1.5 million points (1440 x 1080) in a 450-ms scan to provide highly detailed point clouds and true per-pixel measurement. The device's ambient light suppression further optimizes results.

The camera's range and field of view (FoV) give users the versatility to scan objects both large and small. With a range of 1,280 mm, the camera can encompass FoVs as small as 723 x 530 mm and as large as 1626 x 1312 mm.

3S40 3D sensor: At a Glance

- **Plug and play integration** – Easily paired with Zebra's powerful 4Sight EV7 vision controller and Aurora software. Just point the 3S40 device at a scene to capture an accurate high-density point cloud.
- **Large scanning volume** – The 3S40 3D sensor's scanning volume ranges up to two meters to capture large and very small objects.
- **Ambient Light Suppression** – 1.5-MP structured light scanning with laser projection and ambient light suppression delivers optimal results.
- **Power-over-ethernet (PoE) and 24V powering options** – A single PoE cable provides both power and a data connection.
- **Lightweight and energy efficient** – Thanks to its low weight, the 3S40 3D sensor can be mounted directly onto a robotic arm to allow robotic hand-eye applications.
- **Dust and waterproof** – Featuring protection class IP65, the 3S80 sensors are dust-tight and protected against low-pressure jets of water coming from any direction and at any angle.

The 3S40—Vision without limits. Experience the difference with Zebra.
For more information, visit www.zebra.com/3S-series

Sophisticated Performance, Simple Implementation

Zebra's 3S40 3D sensor supports GigE Vision standards for plug-and-play integration with existing machine vision systems. Though 24V power is an option, the sensor's PoE+ connector allows a single cable to provide both electric power and data connection. Users simply plug in and point the camera at a scene to begin capturing accurate high-density point clouds of static objects.

Powered by Zebra Aurora™ Software

Every 3S40 3D sensor is bundled with Zebra Aurora Design Assistant™ or Zebra Aurora Vision Studio™ software to quickly configure and deploy complex deep learning and traditional machine vision applications. Add Zebra's 4Sight EV7 controller for demanding single high-rate or multi-camera imaging and machine vision applications.

Easy to Deploy and Run

Zebra's Aurora Design Assistant and Aurora Vision Studio software makes it easy for users to deploy and run applications without having to learn or implement multiple software environments. Both software platforms enables the 3S40 to leverage a deep collection of tools for image capture, processing, analysis, annotation, display and archiving.

Deep Learning to Further Enhance Solution Quality

Use the 3S40 with Zebra's advanced deep learning tools to solve complex machine vision problems that were previously impossible to achieve with traditional tools. Locate complex and irregular surface defects and enable other complex 3D vision tasks to improve the quality and operational efficiency of your workflow.

Zebra 3S Series Lineup

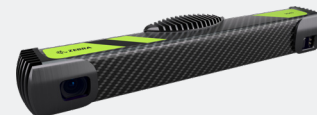

3S40



3S80-4M

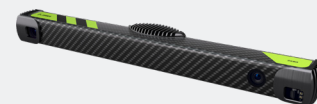

3S80-4L

Specifications

3S40-4M

Device Characteristics

Dimensions	16.4 x 2.7 x 3.4 in 416 x 68 x 86 mm
Weight	2 lbs / 950 g
Baseline	13.8 in / 350.0 mm
Power	PoE+ or 24 V
Data connection	1 Gbit Ethernet

Performance Characteristics

3D sensing technology	structured light
Output data	3D points (x y z) normals (x y z) depth map (z) texture (grayscale intensity) confidence
Scanning range	34–85 in / 870–2150 mm
Optimal scanning distance (sweet spot)	49 in / 1245 mm
Scanning area (at sweet spot)	23.1 x 17.5 in / 588 x 444 mm
Scanning time	from 450 ms
Operation Mode/Scene	Scanner/Static
Resolution	1.5 million 3D points (1440 x 1080)
Point-to-point distance (at sweet spot)	0.03 in / 0.82 mm
Calibration accuracy (1 σ)	0.2 in / 0.5 mm
Temporal noise (1 σ)	0.2 in / 0.45 mm
Maximum fps	2 fps

User Environment

Temperature working range	full: 32–104° F / 0–40° C optimal: 72–77° F / 22–25° C
---------------------------	---

3S40 Field of View

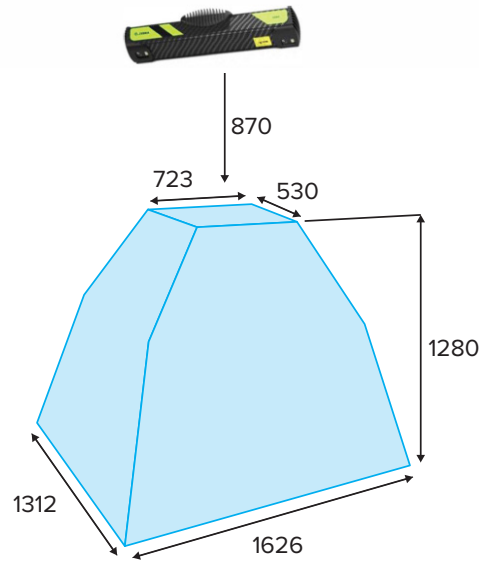

NA and Corporate Headquarters
+1 800 423 0442
inquiry4@zebra.com

Asia-Pacific Headquarters
+65 6858 0722
contact.apac@zebra.com

EMEA Headquarters
zebra.com/locations
contact.emea@zebra.com

Latin America Headquarters
zebra.com/locations
la.contactme@zebra.com